

FBCC36SQ - Full Base Corner SQ Adjustment Instructions

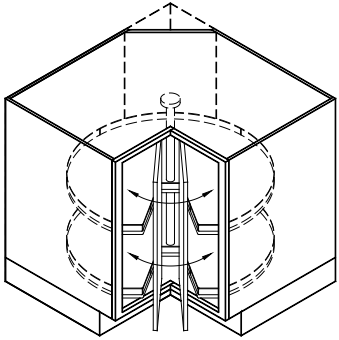

Doors can be adjusted independently of each other in all directions. Before making adjustments, make sure the corner cabinet is aligned exactly. If you use adjustable cabinet feet, special attention should be paid to adjusting the middle foot for support of the pole weight.

When adjusting, first correctly align the right door following the steps illustrated below. Then adjust the left door in the same sequence. Adjustments may require some "trial and error" to match both sides properly.

Adjustment Instructions For:

- Cornerstone Framed
- Cornerstone Inset (requires 1/8" recess for bottom shelf)
- Millennia Frameless – (doors designed to drop 5mm when opening)

Door Rotation

1. Do the doors spin freely within the cabinet?

- Y –
- N – Continue to #2

2. Are doors dragging at the bottom/top?

- Y – Make sure the cabinet is installed square
- N – Adjust Height (see diagram below)

3. Does the unit spins slowly or makes a "grinding" or "squeaking" noise (Euro version)?

- Y – Ensure travel pin at the top bracket of pole was removed at installation, and / or ensure top bracket is secured to underside of the countertop
- N –

4. Are the doors properly adjusted for reveals/gaps?

- Y –
- N – See #7 below

4A. Inset: is the face frame rail 1/8" above the cabinet floor?

- Y –
- N – Make sure the cabinet is installed square

5. Did this correct the issue?

- Y –
- N – See below

6. Is center pole plumb? (Use level against it.)

- Y –
- N – Make sure the cabinet is installed square

7. Are the door gaps/reveals equal and correct?

- Y –
- N – Use a screwdriver to adjust according to the diagrams below. Each door has three adjustment points; Depth adjusts from the back, Lateral adjusts from the side and Height adjusts via a white nylon set screw.

-- See Page 2 for instructions on adjusting the closing speed of doors --

DEPTH ADJUSTMENT

Aligns the doors plumb to the cabinet face.

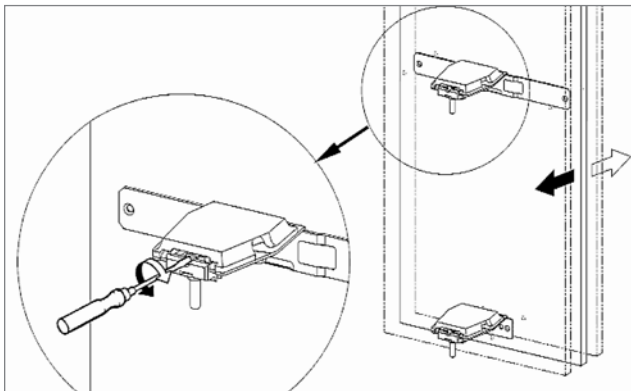

LATERAL/SIDE ADJUSTMENT

Adjusts the door overlay.

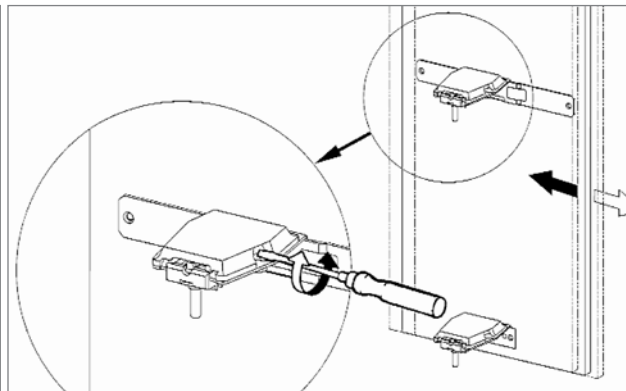

HEIGHT ADJUSTMENT

Adjusts distance between the door and countertop.

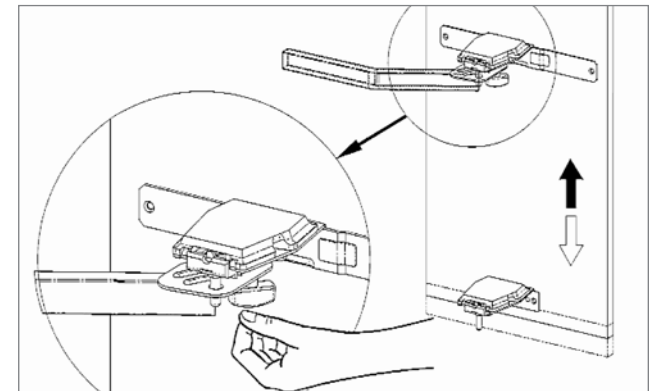

Closing Speed of Doors

Recommended tools: #2 Pozi screwdriver and needle-nosed pliers.

1. Do the doors automatically push themselves closed when revolved into the opening?
 - **Y** –
 - **N** – Adjust tension on self closing dampener spring, using screwdriver (See top right)
2. Did this correct the issue?
 - **Y** –
 - **N** – See below
3. Are the doors heavy?
 - **Y** – MDF, or hardwood core doors may be heavier than other wood doors; closing spring adjustment may be required
 - **N** –
4. Does this correct the closing speed issue?
 - **Y** –
 - **N** – The SuzieQ has spring tensioning points on the underside of the unit, shown at bottom right.
 - a) Loosen the adjustment screw to allow slack on the spring.
 - b) Remove spring using needle nose pliers.
 - c) Tension spring so that it is stretched further on tabs.

CLOSING SPEED OF DOORS

You can adjust the closing speed of the doors without removing the fitting. Turn adjustment screw clockwise for quicker door closing. For slower door closing, turn adjustment screw counterclockwise.

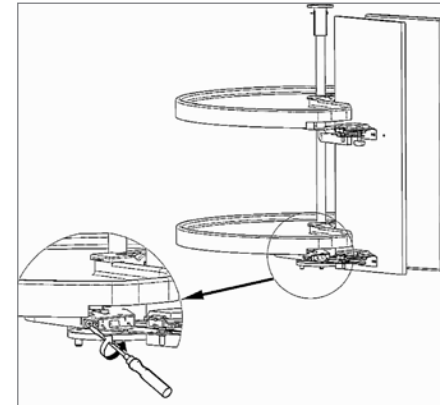

TRANSPORT LOCK

Remove securing pin located at the upper pole bearing prior to operation.

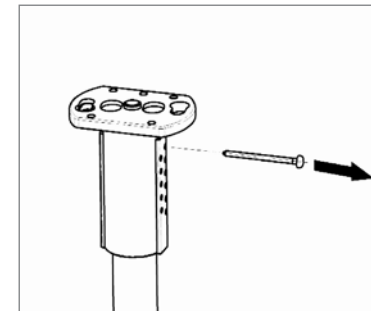

TENSIONING

B-1: Least | A-1: Greater
B-2: Greater Still | A-2: Greatest

Further increase in the closing force can be achieved by repositioning the tension spring.

The tension spring can only be repositioned when the fitting is removed.

